

REVISIONS		
NO.	DESCRIPTION	DATE

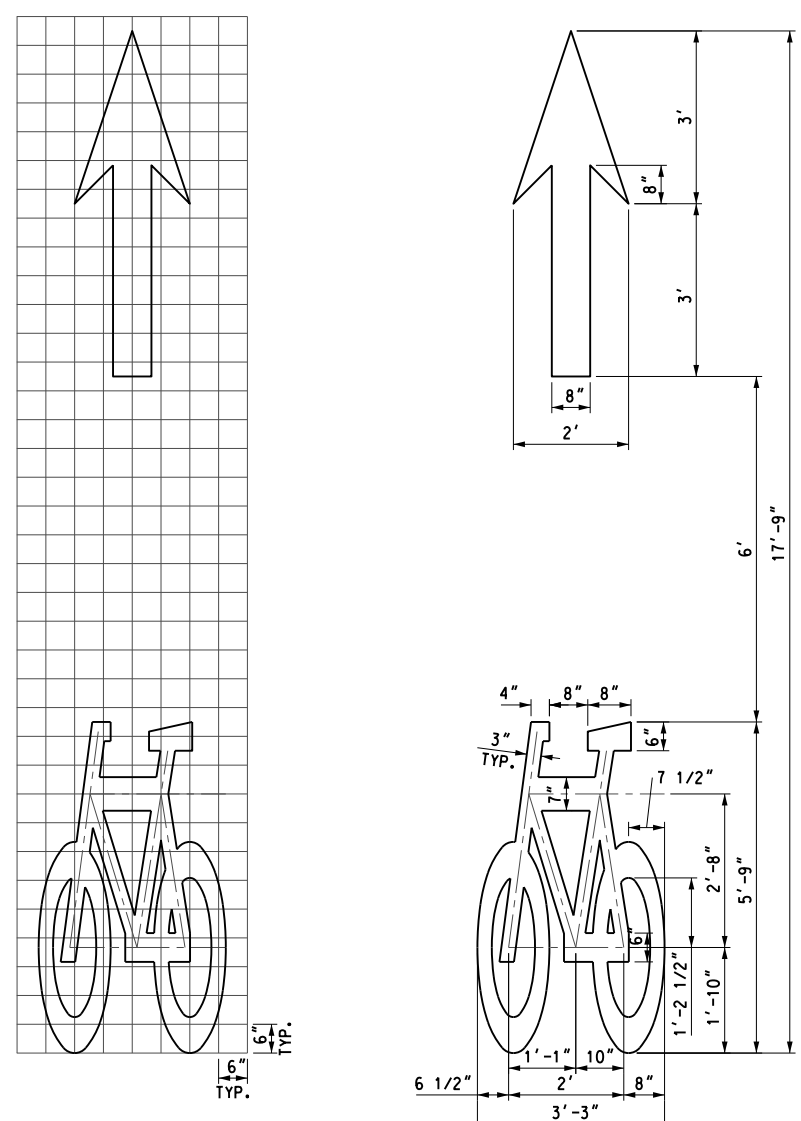

BIKE LANE SYMBOL DETAIL

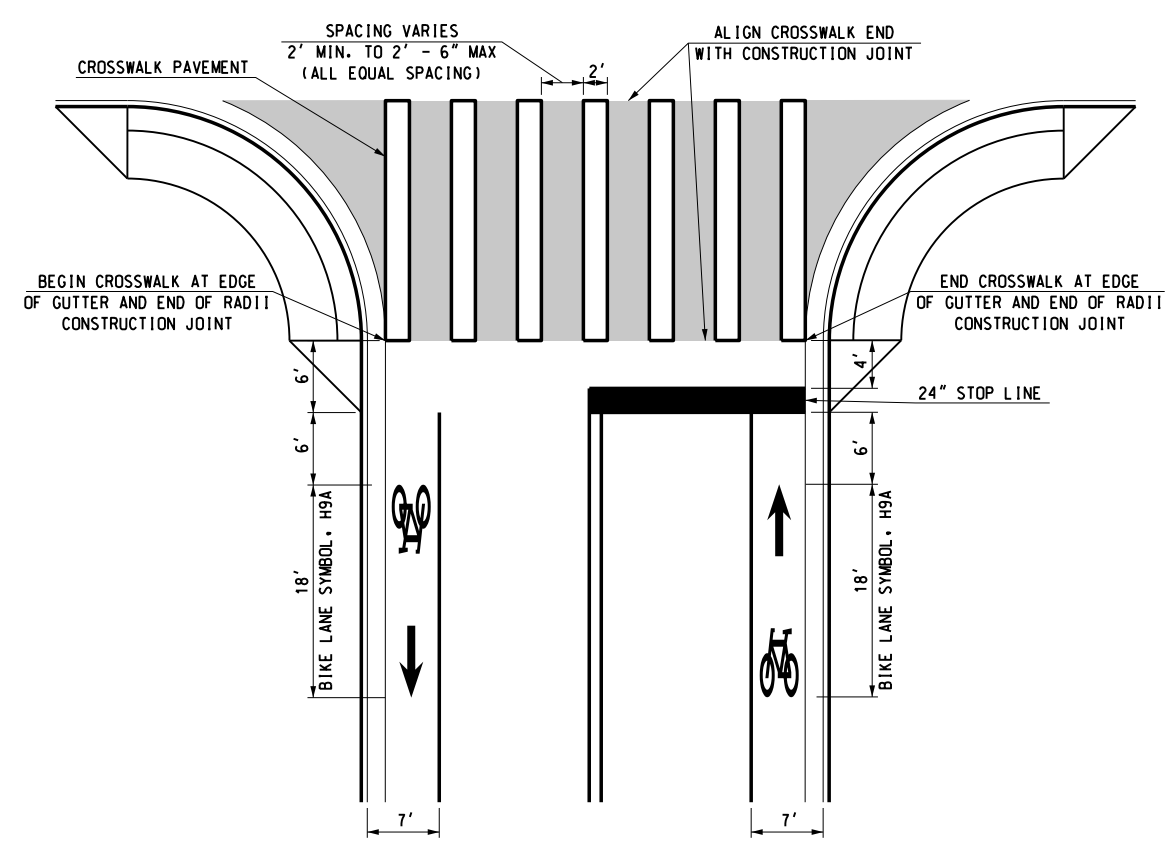

I-13-15 G:\0\Projects\1-24\7B Downtown Blvd WP 5JC Task 6\CAD\CROSSWALK BIKE DETAIL.dgn

R. Wayne Russell
 R. WAYNE RUSSELL, P.E. # 16030
 C.A. # 1160, RENEWAL 06-30-17

11-13-15
 DATE

Traffic Engineering Consultants, Inc.
 6000 S. Western, Suite 300 - Oklahoma City, OK 73139,
 Ph: 405-720-7721, Fax: 405-720-9848, Web: www.tecok.com

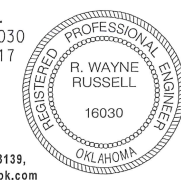

Design	RWR	11-13-15
Drawn	SB	11-13-15



TYPICAL CROSSWALK AND BIKE LANE SYMBOL DETAIL

State Job No. 17428(89) Sheet No. T11